



Rectangular or Spiral Double Wall Duct & Fittings

ECO Products Double Wall Pipe is constructed with a 2" thick fiberglass insulation blanket, sandwiched between an outer spiral metal pressure shell, and an inner plain (or perforated) metal liner.

Advantages to double wall duct systems include fan noise reduction, cross talk control, assured thermal conductivity, and permanent insulation protection.

Acoustical Advantages

- Fan noise reduction and cross-talk control
- High transmission loss through duct walls
- Reduction of system noise
 - Noise reduction rating based on actual condition of installation

Thermal Insulation Advantages

- Assured thermal conductivity
- Vapor barrier integrity
- Permanent protection of the insulation
- Assured uniformity

Mechanical Advantages

- Lower friction loss penalty for noise reduction
- Predictable friction factor
- Automatic expansion joint
- Sheet metal screws do not project into air stream
- Improved appearance
- Double fire protection
- Space saving

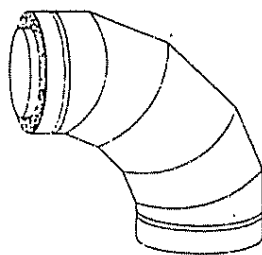
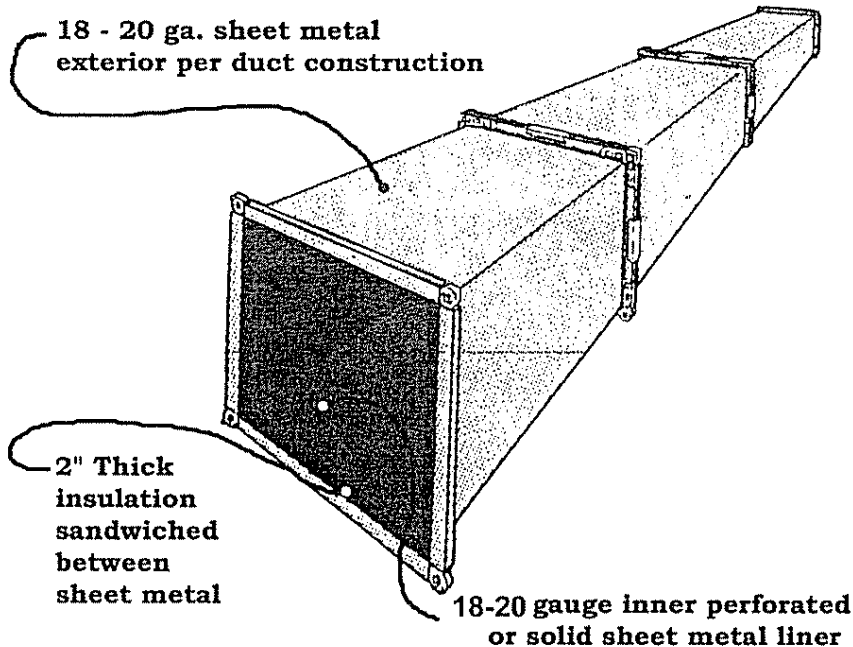

- Outer Metal Pressure Shell
- 2" Thick Insulation
- Internal plain metal liner or
- Internal perforated metal liner

5200 E. La Palma
Anaheim, CA 92807
(888) Eco-Duct (326-3828)
Fax: 714-970-3976



21005 Cabot Blvd.
Hayward, CA 94545
(510) 670-0326 Phone
(510) 670-0384 Fax

URL: www.ecoduct.com
Email: Sales@ecoduct.com